



Dishwashers

pluvia

260

270

280

 **ELETTROBAR**

The Benefit Makers

**ELETTROBAR**

**the benefit makers**



**pluvia**

In our history, over 40 years long, we have built more than half a million dishwashers; this outstanding experience is the key of our success: it gives us the knowledge to improve day by day our capability to design and build products that deliver to professional caterers real benefits at a good price.

We are conscious that environmental problems are more and more important and everybody must play their role: our products use, therefore, advanced technologies in order to reduce the consumptions of water, energy and chemical products. A real help to the Earth and good savings for you.

## First benefit: performances

Improving the quality of Elettrobar's washing? Mission accomplished! With our patented EWT (Elettrobar warewashing technique) we have improved our washing results by 10%\*:

Clean dishes, lower energy consumption, lower noise: these are the results of the EWT circuit with double flow pump that reduces the loss of hydraulic power; the highly appreciated Elettrobar Technological Arm allows a perfect distribution of the water over the rack; it's very light, and for this reason it needs less energy to turn and it is also extremely easy to dismantle and clean.

pluvia



## Second benefit: running costs

Washing and saving over 350 € per year; a dream? No, Elettrobar Technology! Pluvia is equipped with the patented EDS (Elettrobar Drain System) device. It is based on the physical principle of communicating vessels and forces the water to go through the dirtiest areas of the tank before being drained away, helping to keep the tank cleaner. This leads to a tank volume reduction as well as a reduction in detergent concentration. Accurate studies gave us the opportunity to reduce the rinse water consumption and increase your savings.

## Third benefit: ecology

Washing dishes while protecting the environment; impossible? Not with Pluvia! New patented technologies for washing and draining, improved rinse and accurate studies to minimize any kind of loss, give you a dishwasher that saves up to 14.000 lt of water, 70 Kg of chemical products and 700 Kwh\* a year. A great saving for you but, more important, a real help to the safeguard of our environment.

\* Comparison with Niagara 51, 60 cycles per day, 2 services, 320 days per year.

**pluvia**

### **Fourth benefit:** **simplicity**

A dishwasher that may be used even by a child? Pluvia by Elettrobar! Electromechanical user-friendly control panel, three single action push buttons and three control lamps.

You can train the machine operator in a very short time. The system also includes a Thermostop function assuring the hygiene of your dishes. Low possibility of mistakes and misuse damages even with a high turnover of operators.

Pluvia 260 can be supplied with built in water softener; adding the salt is very easy, thanks to the filling cap in the tank.



### **Fifth benefit:** **ease of cleaning**

End service cleaning in just half of the time? With Pluvia you can! Any single detail has been designed to make this unpleasant operation easier: tank and rack drives are fully deep drawn, integral surface strainers are pipe-free, all washing chambers have no pipes inside, all pumps are self emptying and the pressostat intake is placed outside the tank (Elettrobar patent). This all reduces the required time for cleaning of at least 10'each time: enjoy your spare time!

### **Sixth benefit:** **ergonomics**

A better efficiency of your personnel; utopia? No, Pluvia by Elettrobar. Many useful details reduce the operator fatigue and improve their efficiency: moving the racks is made easier by the embossed drives in the counterdoor and the strength required for opening a door or lifting a hood is limited to 3 Kg only (40% less, Elettrobar patent). The compact overall dimensions, despite the great usable internal volume, allow an easy positioning in any kitchen.

# pluvia 260

## THE PRODUCT

Economic and versatile dishwasher; equipped with a 380 mm tall door can wash even pizza plates and Gastronorm 1/1 trays with a maximum output of 720 plates/hr. Two selectable cycles allow you to adapt the washing time to the soil level and our special soft start treats smoothly even the most fragile pieces of crockery.

Pluvia 260 can hardly be heard: it is four time less noisy than a traditional machine and its low consumption make you save over 350 € per year\*.

## TECHNICAL DATA

Dimensions	mm	600 x 600 x 820
Usable opening	mm	380
Tank volume	lt	15
Wash cycles duration	sec	90-120
Water consumption	Lt/rack	2,9
Wash pump power	W	600
Electrical power at 400V/50Hz/3ph	W	5.450
Electrical power at 230V/50Hz/1ph	W	3.550
Detergent dispenser		Kit

Standard equipment	1 plates rack	780072
	1 cutlery insert	712019

*Continual improvements may supersede.*



\* Comparison with Niagara 51, 60 cycles per day, 2 services, 320 days per year.

# pluvia 270



## THE PRODUCT

Ergonomic and versatile dishwasher; equipped with a 380 mm tall door can wash even pizza plates and Gastronorm 1/1 trays with a maximum output of 720 plates/hr. Two selectable cycles allow you to adapt the washing time to the soil level and our special soft start treats smoothly even the most fragile pieces of crockery. Pluvia 270 can hardly be heard: it is four times less noisy than a traditional machine and its low consumption makes you save over 350 € per year\*. The perfect choice for all restaurants with high number of meals served and limited space in the kitchen.

## TECHNICAL DATA

Dimensions	mm	600 x 600 x 1.400
Usable opening	mm	380
Tank volume	lt	15
Wash cycles duration	sec	90-120
Water consumption	Lt/rack	2,9
Wash pump power	W	600
Electrical power at 400V/50Hz/3ph	W	5.450
Electrical power at 230V/50Hz/1ph	W	3.550
Detergent dispenser		Kit

Standard equipment	1 plates rack	780072
	1 cutlery insert	712019

*Continual improvements may supersede.*

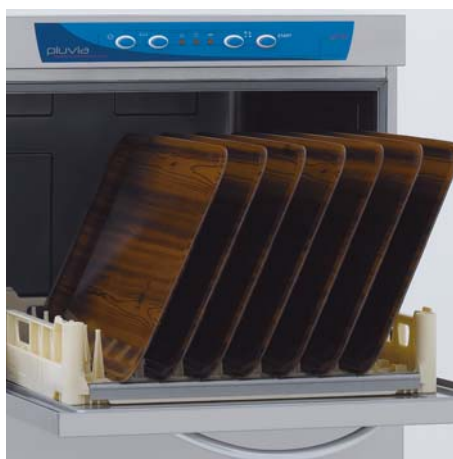

\* Comparison with Niagara 51, 60 cycles per day, 2 services, 320 days per year.

# pluvia 280

## THE PRODUCT

Ergonomic and versatile hood-type dishwasher (hood opening 410 mm) can wash pizza plates and Gastronorm 1/1 trays; the theoretical output can reach 900 plates/hr\*\*.

Two selectable cycles, in-line or corner installations are possible without modifications.

The reduced hood lift strength and the easy to clean construction make the operators' fatigue lower and their efficiency higher. Twice less noisy than an old generation unit. Its reduced water and energy consumptions make you save over 250 € per year\*\*\*.

## TECHNICAL DATA

Dimensions	mm	640 x 740 x 1.500
Usable opening	mm	410
Tank volume	lt	15
Wash cycles duration	sec	90-120
Water consumption	Lt/rack	2,9
Wash pump power	W	600
Electrical power at 400V/50Hz/3ph	W	8.150
Electrical power at 230V/50Hz/1ph	W	3.350
Detergent dispenser		Kit

Standard equipment	1 plates rack	780072
	1 cutlery insert	712019

*Continual improvements may supersede.*



\*\* Equipped with the special 983030 optional plates rack.  
\*\*\* Comparison with E 78, 80 cycles per day, 2 services, 320 days per year.

# pluvia 260

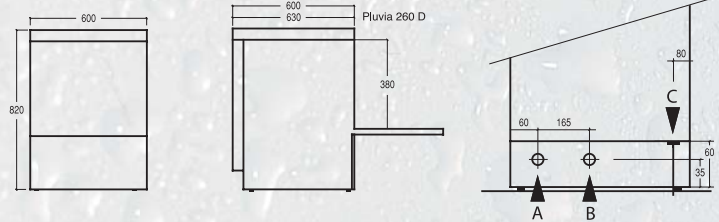

# pluvia 270

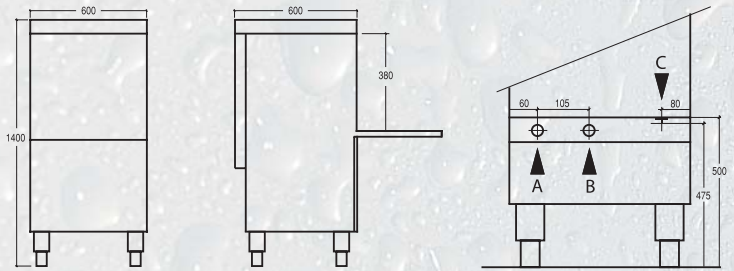

# pluvia 280

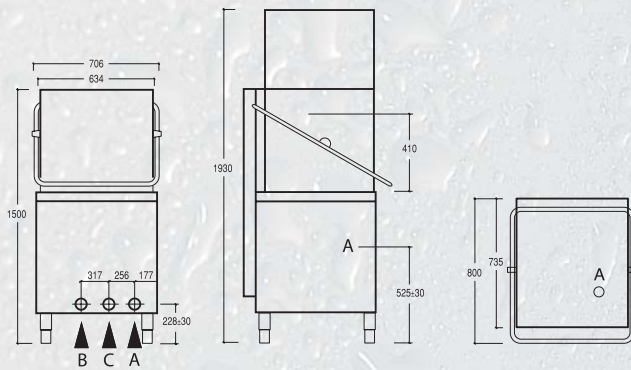

A		Ø 50 mm M
B		Ø 3/4" GAS M
C		

**ELETTROBAR**

