



DOMINA PRO 900 - BRATT PANS

BRG98A



S/S BOWL, GAS MONOBLOC

TECHNICAL DATA:

External dimensions - WxDxH (cm)	80x90x85
Tank capacity (lt-GN)	80
Total power (kW)	20
IPX5	●

ADDITIONAL TECHNICAL DATA:

Tank dimensions - WxDxH (cm)	79x69x20
Power Burners (kW)	20
Electric elements (kW)	0,02
Supply (N)	230V 1N 50Hz
Weight (kg)	164
Volume (m3)	1,1

The tank has AISI 304 18/10 stainless steel walls and bottom, rounded corners and the shaped front part to facilitate unloading and cleaning operations. The stainless steel lid is balanced and has strong stainless steel AISI 304 hinges. Easy manual tilting of the tank through an ergonomic front handle. Water load tap placed on the front of the unit.

Gas versions: stainless steel burner with multiple arms for even more heat diffusion; gas valve with thermocouple, thermostatic temperature control (90-320 °C).

Electric versions: armoured heating elements in stainless steel on the external bottom of the tank; thermostatic control (50-300 °C).

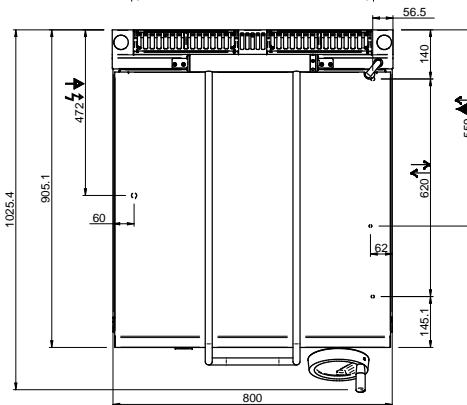
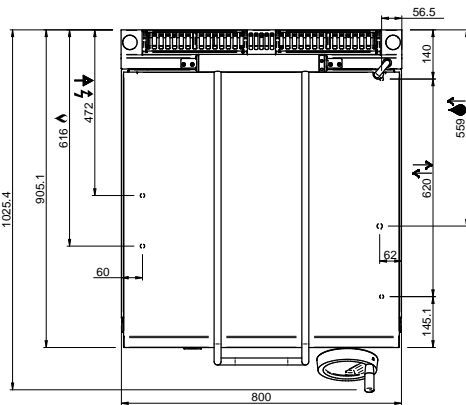
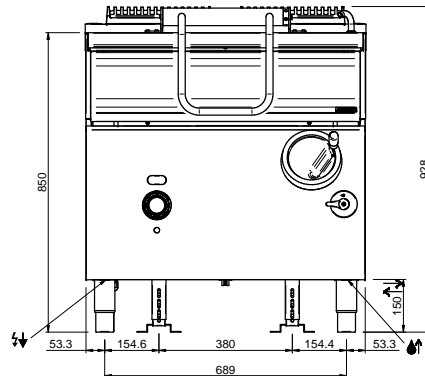
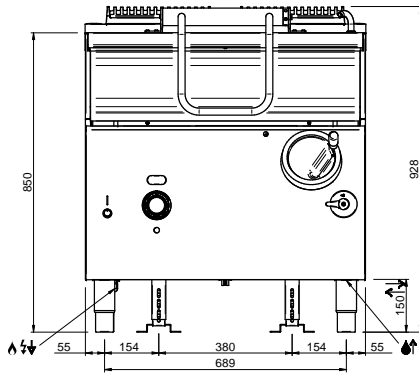

LEGENDA SIMBOLI / LEGEND



INGRESSO GAS / GAS INLET
(EN 10226-1) Ø M 1/2"



INGRESSO ACQUA /
WATER INLET Ø M 1/2"



ATTACCO EQUIPOTENZIALE /
EQUIPOTENTIAL



ALIMENTAZIONE ELETTRICA /
POWER SUPPLY



SCARICO ACQUA / OLII
WATER / OILS DRAIN



REGOLAZIONE PIEDINI /
FEET ADJUSTMENT (h 0/+50)
/ TOP VERSION (h 0/+5)