

Mod. E7TPB

Mod. E7TPM



Macros 700



Zone 4
kW 2,25



TOT. kW 9



380 - 415 V3N~



OPTIONAL

2P 400 2 porte con maniglia spessore 20/10 per i modelli con mobile / 2 doors with handle of 20/10 thickness for cabinet versions / 2 portes avec poignée de épaisseur 20/10 pour les modèles sur meuble / 2 Türen mit Griff Stärke 20/10 für Modelle mit Möbel

CARATTERISTICHE TECNICHE E FUNZIONALI

Piano di lavoro e pannelli frontali in acciaio inox AISI 304. Superficie in speciale acciaio ad alto spessore con 4 zone di cottura indipendenti. Riscaldamento tramite resistenze elettriche a filamento, fissate sotto la piastra ed attivabili tramite regolatori di energia. Spia elettrica di funzionamento. Piedini regolabili.

TECHNICAL AND FUNCTIONAL FEATURES

Worktop and front panels made of AISI 304 stainless steel. Special extra thick steel surface with 4 independent cooking zones. Heating by filament resistances installed under the plate and enabled by power regulators. Power light. Adjustable feet.

CARACTÉRISTIQUES TECHNIQUES ET FONCTIONNELLES

Plan de travail et panneaux frontaux en acier inoxydable AISI 304. Surface en acier spécial de haute épaisseur avec 4 zones indépendantes de cuisson. Chauffage par l'intermédiaire de résistances électriques à filament, fixées sous la plaque et activables par le biais de régulateurs d'énergie. Voyant électrique de fonctionnement. Pieds réglables.

TECHNISCHE UND FUNKTIONELLE EIGENSCHAFTEN

Arbeitsfläche und Vorderfront aus rostfreiem Edelstahl AISI 304. Oberfläche aus besonders starkem Spezialstahl mit 4 unabhängigen Kochzonen. Erwärmung über elektrische Heizfadenwiderstände unterhalb der Platte, die mit einem Energieregler eingestellt werden können. Elektrische Betriebsleuchte. Höhenverstellbare Füße.

E	connessione elettrica / electric connection / branchement électrique / Elektrischer Anschluss	380 - 415 V3N~	kW 9
----------	--	----------------	-------------

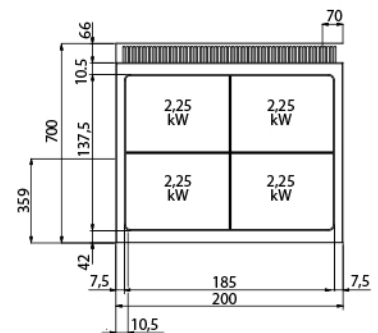
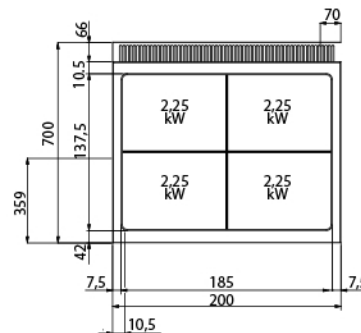
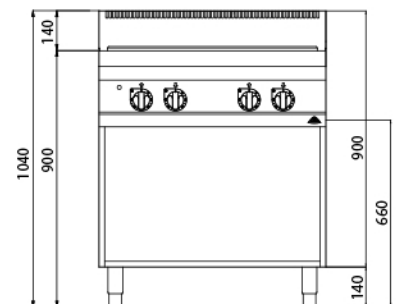
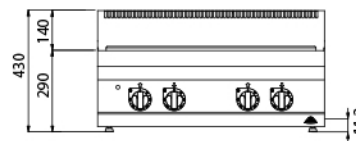

33 LEVENTI STR. PERISTERI, ATHENS 121 32, GREECE
TEL.: 0030 210 5723111, FAX: 0030 210 5723113
e-mail: sales@varanakis.com, www.varanakis.com