

DISTFORM
FOODSERVICE TECHNOLOGY



Packers
TekVac

Chamber vacuum packers, with the most advanced technology



A complete range of vacuum packers that uses the most advanced technology on the market. Conceived and designed in collaboration with top chefs who are leaders in the application of the latest cooking techniques and management systems.

With TekVac you get perfect vacuum packing with maximum guarantees for sealing.

Vacuum packing makes it possible cook and/or store food in the vacuum bag due to the absence of oxygen. This prevents the propagation of aerobic bacteria and ensures greater food safety.

iVac iVac (Intelligent Vacuum) Packing liquids has never been so easy



Reduce the maintenance, repair and consumption costs of food packing with the newly patented iVac (Intelligent Vacuum). This new sensor-controlled packing system allows our TekVac machines to carry out intelligent food packing and automatically selects the optimum vacuum level for each product. iVac is ideal for packing liquids and moist and porous foodstuffs.

The iVac makes it possible to pack food products without the need for supervision and optimises the timing of the packing cycle.

Process for packing liquids with the iVac:

- 1 Start the liquid packing process
- 2 The liquid begins to boil
- 3 The volume of the liquid increases
- 4 The iVac detects boiling and stops the pump automatically

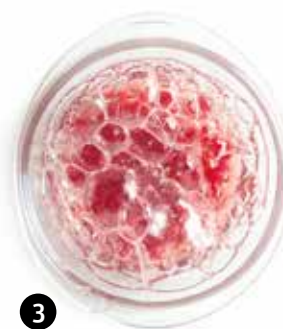



Auto Clean Oil

Save time and money on oil changes

The condensation of the oil vapour which is given off during the packing process reduces the efficiency of the vacuum pump. The Auto Clean Oil system eliminates the condensed water and thereby prolongs the working life of both the oil and the vacuum pump. In this way, we achieve considerable cost and time savings in the maintenance of the machine. It is recommendable to carry out an Auto Clean Oil cycle once a week.



Calibration

Making you packer 100% precise in a matter of seconds

Height above sea level, variations in atmospheric pressure and changes in the weather can all affect the precision of the vacuum. Correct calibration ensures that when you need a 100% vacuum with respect to the atmospheric pressure at the place where sealing is performed that is exactly what you will get. For this reason, the whole range of sensor-controlled TekVac packers now come equipped with the calibration function as a standard fitting; always guaranteeing a perfect vacuum.



Wire-free sealing bar

Cleaning in half the time

The special design of the wire-free sealing bar and the construction of the packing chamber, which is made of stainless steel and has rounded corners, make cleaning the packer much easier and quicker. Thanks to the special design of the sealing bar.



Soft Air

For packing delicate or special food products

Soft Air allows the progressive entry of air so that the vacuum bag adapts better to the product during the packing process. It is ideal for products that could deform or break during packing. Achieve aesthetically perfect packing which is ideal for exhibiting food products for sale when presented either in line or in display cabinets.



Packing in a modified atmosphere

For fresh or delicate food products

When packing in a modified atmosphere, you will be able to pack any type of food product respecting food safety regulations and also guaranteeing the quality of even the most delicate fresh foods: fish, seafood, vegetables, dairy products... The inert gas used in this process also protects fragile food products which could otherwise deform or break during the packing process: chips, salads, pasta...



Vac +

Extra vacuum for porous foodstuffs

With the Vac+ function, you can add additional vacuum time once the 100% vacuum level has been reached in order to force the air out of porous foodstuffs. One very interesting application of the Vac+ function is that of impregnation: a technique by which the air inside porous foodstuffs (such as some types of fruit) is replaced by a liquid which may modify its colour and/or taste but which maintains its texture.



Range of **sensor-controlled** vacuum packers



TVA310B2

External dimensions
Width x Depth x Height

Chamber dimensions

Vacuum pump

Voltage

Power

Length of sealing bar

430 x 461 x 352 mm

330 x 330 x 90 mm

BUSCH 6 m³/h

230/1/50 V/N/Hz

0,25 kW

310 mm



TVA411B2 / TVA410B2

525 x 565 x 457 mm

430 x 430 x 180 mm

BUSCH 10 / BUSCH 20 m³/h

230/1/50 V/N/Hz

0,37 kW / 0,75 kW

410 mm



TVA412B3

External dimensions
Width x Depth x Height

Chamber dimensions

Vacuum pump

Voltage

Power

Length of sealing bar

835 x 590 x 1031 mm

700 x 430 x 180 mm

BUSCH 40 m³/l

400/3/50 V/L+N/Hz

1,125 kW

410+410 mm





TVA430B2

665 x 590 x 460 mm
 570 x 450 x 180 mm
 BUSCH 20 m³/h
 230/1/50 V/N/Hz
 0,75 kW
 430 mm



TVA432B2

665 x 590 x 460 mm
 570 x 450 x 180 mm
 BUSCH 20 m³/h
 230/1/50 V/N/Hz
 0,75 kW
 430 + 430 mm



TVAX1B40 / TVAX1B63

930 x 630 x 945 mm
 800 x 500 x 200 mm
 BUSCH 40 / BUSCH 63 m³/l
 400/3/50 V/L+N/Hz
 1,125 kW / 1,5 kW
 480+700 mm



TVAX2B63 / TVAX2B10

1220 x 730 x 945 mm
 1000 x 600 x 200 mm
 BUSCH 63 / BUSCH 100 m³/l
 400/3/50 V/L+N/Hz
 1,5 kW / 2,25 kW
 580+900 mm



Range of **time-controlled** vacuum packers



TVT310B2

External dimensions
Width x Depth x Height

410 x 450 x 330 mm

Chamber dimensions

330 x 330 x 90 mm

Vacuum pump

BUSCH 6 m³/h

Voltage

230/1/50 V/N/Hz

Power

0,25 kW

Length of sealing bar

310 mm



TVT411B2 / TTV410B2

540 x 565 x 445 mm

430 x 430 x 180 mm

BUSCH 10 m³/h / BUSCH 20 m³/h

230/1/50 V/N/Hz

0,37 / 0,75 kW

410 mm



TVT412B3

External dimensions
Width x Depth x Height

835 x 590 x 1031 mm

Chamber dimensions

700 x 430 x 180 mm

Vacuum pump

BUSCH 40 m³/h

Voltage

400/3/50 V/L+N/Hz

Power

1,125 kW

Length of sealing bar

410+410 mm





TVT430B2

650 x 585 x 445 mm
 570 x 450 x 180 mm
 BUSCH 20 m³/h
 230/1/50 V/N/Hz
 0,75 kW
 430 mm



TVT432B2

650 x 585 x 445 mm
 570 x 450 x 180 mm
 BUSCH 20 m³/h
 230/1/50 V/N/Hz
 0,75 kW
 430 + 430 mm



TVTX1B40 / TVTX1B63

930 x 630 x 945 mm
 800 x 500 x 200 mm
 BUSCH 40 / BUSCH 63 m³/l
 400/3/50 V/L+N/Hz
 1,125 kW / 1,5 kW
 480+700 mm

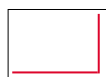

TVTX2B63 / TVTX2B10

1220 x 730 x 945 mm
 1000 x 600 x 200 mm
 BUSCH 63 / BUSCH 100 m³/l
 400/3/50 V/L+N/Hz
 1,5 kW / 2,25 kW
 580+900 mm



Intuitive panels, for visual monitoring of all the packing processes

Sensor-controlled panel



- A Percentage vacuum
- B Extra vacuum time (Vac+)
- C Injection of inert gas
- D Sealing time
- E Programme memory
- F Stop vacuum cycle
- G Increase the value
- G+H Calibrate the packer
- H Reduce the value
- H+I Auto Clean Oil
- I Progressive intake of air (Soft Air)
- J On/Off/Cancel cycle

A+G When the 100% level has been reached, press VAC once more. The light indicates that the “int” of the intelligent vacuum has been activated (iVac).

Time-controlled panel



- A Stop the current cycle
- B Vacuum time
- C On/Off/Cancel cycle
- D Progressive intake of air (Soft Air)
- D+E (-) Auto Clean Oil
- E, F Increase / Reduce values

High quality materials and finishing

high-quality, transparent, methacrylate lid

bag attachment system

aluminium hinges

concealed lid-opening system

polyethylene plate to optimize timing and regulate the height of the product to be packed

wire-free sealing bar

system for self-calibrating machine, only in sensor-controlled models



General specifications

Sensor-controlled models

- Made from AISI 304 stainless steel.
- Removable wire-free sealing bar.
- Chamber with rounded edges for easy cleaning.
- Polyethylene plate inside the chamber that increase the speed of the vacuum and adjusts the working height.
- Intuitive panel: monitoring of all the steps in the packing process
- 2 x 4 mm double seal.
- BUSCH vacuum pump.
- iVac technology for packing liquids.
- Auto Clean Oil, self-cleaning oil system.
- Soft Air, progressive intake of air so that the bag perfectly adapts to the product.
- Vac+, extra vacuum time to force the air out of porous foods.
- Calibration system.
- External vacuum accessory (optional).
- Entry of inert gas. On specified models.
- 99 programme memory.

Time-controlled models

- Countertop machines made from AISI 304 stainless steel.
- Removable wire-free sealing bar.
- Chamber with rounded edges for easy cleaning.
- Polyethylene plate inside the chamber to increase the speed of the vacuum and adjust the working height.
- Intuitive panel: to visually monitor all the steps in the packing process.
- 2 x 4 mm double seal.
- BUSCH vacuum pump.
- Auto Clean Oil, self-cleaning oil system.
- Soft Air, progressive intake of air so that the bag perfectly adapts to the product.

Accessories

• External vacuum kit

With the external vacuum kit, you will be able to vacuum pack and conserve large quantities of food in Gastronorm trays which have been specially strengthened for this purpose.

Using this system, you will be able to maintain the freshness and volume of the product without needing to inject inert gas or to pack it in vacuum bags.



Quick switch connection

With this rapid connection and disconnection system, you will not need any tools to connect the kit to the packer.



Vacuum packing

Connect the external vacuum kit to the closing valve on the lid of the recipient to obtain the vacuum.



Conservation

Easy format for storage and transport.



Opening

The ease of opening with the closing valve on the lid makes it possible to open and close the container as many times as required.



External vacuum accessory



Gastronorm trays specially designed for vacuum packing

Capacity	Depths available
GN 1/1	100, 150, 200 mm
GN 1/2	100, 150 mm
GN 1/3	100, 150 mm



Lids for Gastronorm trays specially designed for vacuum packing GN 1/1, GN 1/2 and GN 1/3



• Table on castors for table-top vacuum packers

External dimensions

700 x 600 x 700 mm

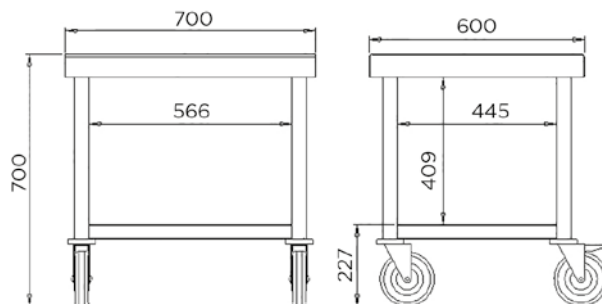

• Bags for vacuum packing

FOR COOKING

Sizes available	Units	Thickness
200 x 300 mm	100 u.	90 microns
360 x 400 mm	100 u.	90 microns

FOR STORAGE

Sizes available	Units	Thickness
200 x 300 mm	100 u.	90 microns
300 x 400 mm	100 u.	90 microns

• Cylinder for filling vacuum bags

Models available:

Diameter 150 mm
Height 150 mm



• Polyethylene plate

Available for:

Model 310
Model 410
Model 430 and 432



• Foam for the core probe

Dimensions available

20 mm x 5 m roll



External vacuum packers are ideal for use in **small businesses**

Light and compact

Distform external vacuum packers are made of stainless steel and are light, robust and compact for easy transport and storage. The vacuum pump ensures the packing of solid products (without humidity), providing optimal protection.

These packers are aimed at small businesses, small food shops, gourmet shops and restaurants. They are also ideal for home use as they make it possible to conserve the whole week's food in perfect condition. Another application is for the electronics industry, which needs to pack electronic plates in order to protect them from dust and humidity.



Ideal for small shops, supermarkets, gourmet restaurants, pubs and bars



TVE010T2

External dimensions
Width x Depth x Height
Pump
Voltage
Power
Length of sealing bar

385 x 254 x 125 mm
10 l/min
230/1/50 V/L+N/HZ
0'3 kW
300 mm

General specifications

- Made of stainless steel.
- Double seal line.
- Seal width 2 x 2.5 mm.
- Automatic sealing on reaching the programmed sealing time.
- Self-lubricating vacuum pump. Power varies according to the model: 10, 20 and 40 l/min.
- Automatic or manual operation.
- Three working programmes: two automatic and one manual.
- Flat membrane panel to facilitate cleaning.
- LED panel indicating the current programme.
- Time-controlled vacuum.
- Regulation of vacuum time from 0.5 to 60 seconds.
- Manual adjustment of the vacuum time.
- Manual opening.
- Only works with embossed bags.

Control panel

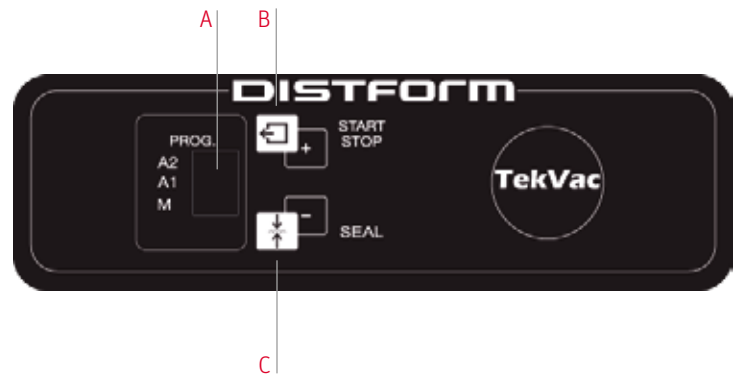

- A Active programme: manual (M), automatic 1 (A1), automatic 2 (A2) / Sealing time
- B Start cycle / Stop cycle / Increase values
- C Modify sealing parameters and choose programme / Reduce values

Accessories

• Channelled vacuum bags

Sizes available	Units
200 x 300 mm	100 u.
250 x 350 mm	100 u.
300 x 400 mm	100 u.



Electric thermo-sealers for **packing foodstuffs in plastic punnets**

Small and easy to use and transport

Thermo-sealers offer a simple and easy solution when it comes to packing products inside perfectly sealed plastic punnets. These thermo-sealers offer the possibility of packing foodstuffs in a rigid format apt for use in hotel and catering, small food business, supermarket and gastronomy contexts.

These thermo-sealers are characterised by their compactness, ease of use and light weight, which make it easy to install them in any corner. They also offer great versatility, with it being possible to interchange different plastic punnet moulds.



TSB150T2

External dimensions (Width x Depth x Height)	230 x 500 x 180 mm
Plate with 1 tray (included)	192 x 137 mm
Plate with 2 trays (optional)	137 x 96 mm
Voltage	230/1/50-60 V/N/HZ
Power	0,45 kW
Roll length	150 mm

General specifications

- Made of stainless steel.
- Compact models, whose small size facilitates their handling, use and transport.
- Simultaneous sealing and cutting of the film.
- The seal is produced by soldering the film to the plastic punnet by applying temperature.

- System for preventing the film from returning in order to facilitate its use.
- All models will be delivered with a roll of film and a mould for single-cavity plastic punnets.



Packing

System to prevent the film from returning and thereby facilitate its positioning for packing.



Sealing

The sealing and cutting of the film take place simultaneously on closing the thermo-sealer.



Cutting

The 2-punnet mould has a groove in the centre to facilitate the cutting of the film and the separation of the plastic punnets.



Different formats

The punnet moulds are easily interchangeable for packing different formats of standard punnets.

Accessories



• Film rolls

Sizes available
150 mm x 150 meters

• Punnet moulds

Plate with 1 tray
192 x 137 mm



Plate with 2 trays
137 x 96 mm



• Box of plastic trays

Sizes available	Units
192 x 137 x 86 mm	400 u.
192 x 137 x 70 mm	500 u.
192 x 137 x 55 mm	500 u.
192 x 137 x 40 mm	500 u.
192 x 137 x 20 mm	600 u.
137 x 96 x 66 mm	1000 u.
137 x 96 x 49 mm	1000 u.
137 x 96 x 32 mm	1000 u.

DISTFORM

FOODSERVICE TECHNOLOGY



www.distform.com
info@distform.com
+34 902 10 18 90