



www.santos.fr



## Grater # 02

For cheese, chocolate, dried fruits, peanuts...



NEW DESIGN

Internationally Patented Models



# Grater #02

## New Grater

New grater for all kinds of cheese, chocolate, peanuts and dried fruits...  
The ideal appliance for cheese shops, supermarkets, pizzerias, cake shops.  
Its new design facilitates cleaning and maintenance.



## NEW Applications

Stainless steel plate for easy cleaning

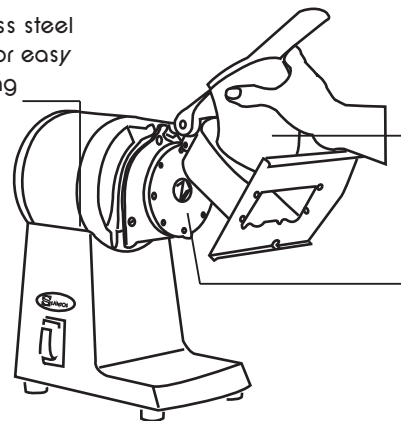

Removable housing for easy cleaning

Discs can be adapted to both new and old grater

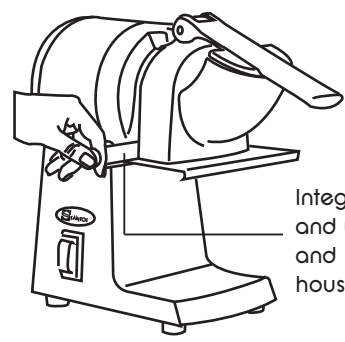

Integrated tool to screw and unscrew the disc and lock the grater housing

# Grater #02

A unique range of discs to grate everything...



www.santos.fr



Option: all the discs for the ice crusher #09 are adaptable to the grater #02.

## Technical specifications

### Motor

Single phase : 100-120V - 50/60 Hz - 650 W - CE, UL  
220-240V - 50/60 Hz - 600 W - CE  
Speed : 1500 rpm (50 Hz)  
1800 rpm (60 Hz)

### Weight

Net 14.5 Kg (32 lbs)  
Shipping 15.5 Kg (34 lbs)

### Appliance :

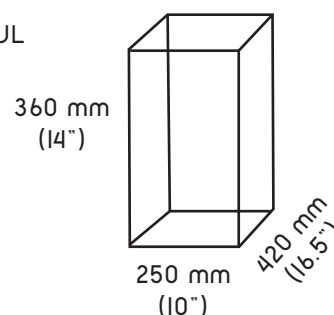

### Shipping box :

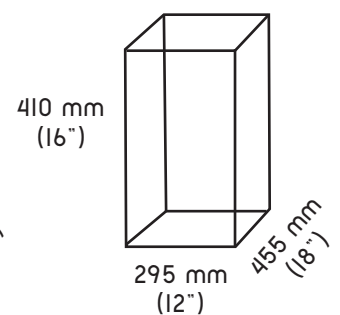

## Safety - Standards - Hygiene

In accordance with the following regulations

- ◆ Machinery directive 2006/42/EC
- ◆ Electromagnetic compatibility 2004/108/EC
- ◆ "Low voltage" directive 2006/95/EC
- ◆ Regulation 1935/2004/EC (contact with food)
- ◆ RoHS directive 2002/95/EC
- ◆ Harmonized European Standards  
NF EN ISO 12100 -1 and 2:2004 - NF EN 60204 -1:2006
- ◆ UL (USA) et cUL (Canada), CE European standards

### Thermal safety

Motor protected by internal thermal detector

### Acoustic safety

Very silent and powerful asynchronous motor

### Hygiene

All removable parts can be put in a dishwasher or easily cleaned with hot soapy water

PRODUCT : 2-YEAR WARRANTY - MOTOR : 5-YEAR WARRANTY

